

PRIME flow COMPAIR® Tower

Product number: 4043069
Configuration: stainless steel

Configuration options

4043069 | stainless steel

✓ Ventilation tower

Stainless steel air outlet including THERMOBOX and condensate drain. Suitable for mounting on the house wall or freestanding in the garden. A wall duct must be provided by the customer (KG 160 with external sleeve).

- depth up to 800 mm below floor level
- tower dimensions H 757 mm x Ø 168 mm
- blower door certified (required opening pressure > 65 Pa)

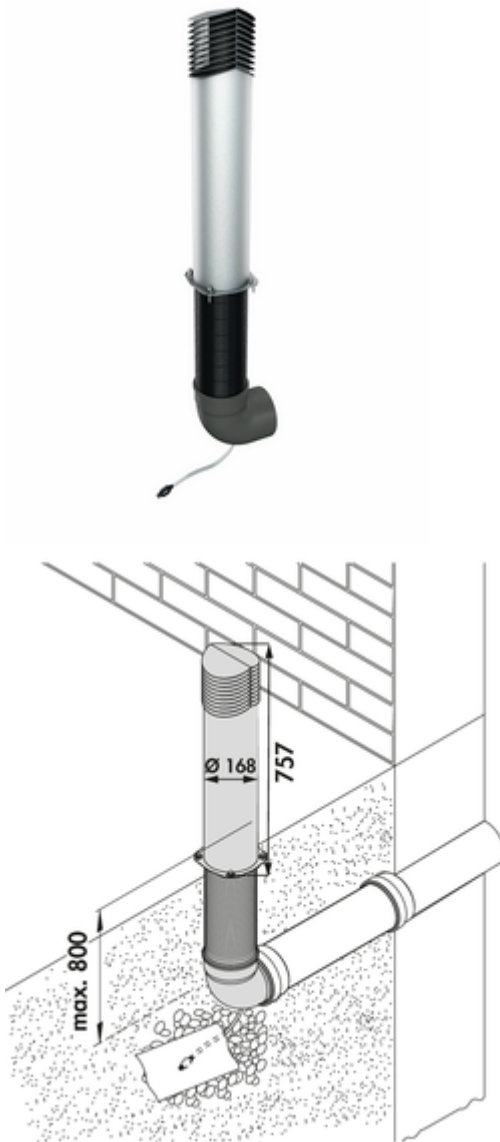

[more infos...](#)

Technical data

Article type	Ventilation tower	More parts	THERMOBOX
Brand	PRIME flow	Consisting of	including THERMOBOX and condensate drain
Height	757 mm	Inner diameter	168 mm
Width	168 mm	Installation depth	800 mm
Material	stainless steel	System dimension	150
Mounting/Fixing	Suitable for mounting on the house wall or freestanding in the garden	Output drive	round
Note	A wall duct must be provided by the customer (KG 160 with external sleeve)	Ventilation system	COMPAIR PRIME flow®
Certification	stainless	Opening pressure	> 65 Pa

Dimensional sketch (PDF)

