

PRIME flow P-BA 150 adapter

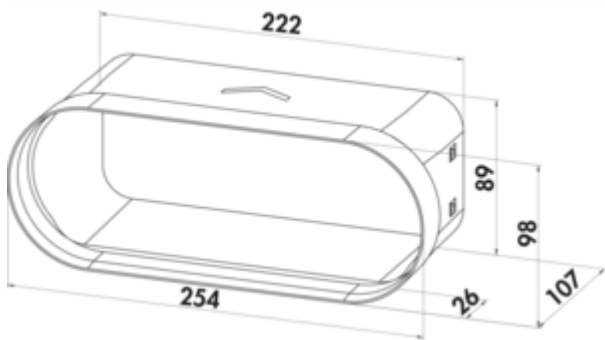

Product number: 4051005
 Configuration: light grey

Configuration options

4051005 | light grey

- ✓ Connecting element
- ✓ N-click system with integrated latching elements
- N-Klick system for secure connection with the universal connector
- enables direct connection of the Naber COMPAIR®-PRIME-flow-system to BORA extractor systems and duct elements
- optimised flow guidance enables loss-free transition

[more infos...](#)

Technical data

Article type	Connecting element	Note	enables direct connection of the Naber COMPAIR®-PRIME-flow-system to BORA extractor systems and duct elements
Brand	PRIME flow	Further	optimised flow guidance enables loss-free transition
Height	98 mm	System dimension	150
Width	107 mm	Output drive	angular round
Mounting/Fixing	N-click system with integrated latching elements	Ventilation system	COMPAIR PRIME flow®

