



Premium 550 EC

Product number: 8012034

Configuration: anthracite, H 312 mm

Configuration options

8012034 | anthracite, H 312 mm

- ✓ Kitchen waste disposals
- ✓ Grinding chamber capacity: 0,98 l
- ✓ stainless steel

Kitchen waste disposer with 2-Stage MultiGrind technology, can be filled continuously. Food residues are crushed into small particles and washed away in seconds. Durable and compact built-in household solution under the sink, without loss of valuable storage space.

The Lift & Latch technology allows for easy installation in new or existing kitchens and is compatible with most sinks. Motor with 0.55 hp, stainless steel grinding elements and integrated air switch in chrome. Overload protection. Suitable for 3½" drains.

Before installing the waste disposal unit, please contact the competent authorities for information on the regional legal regulations!

- Ø 209 mm
- weight 8.12 kg
- grinding chamber capacity 980 ml
- drain connection 380 mm
- 380 watts

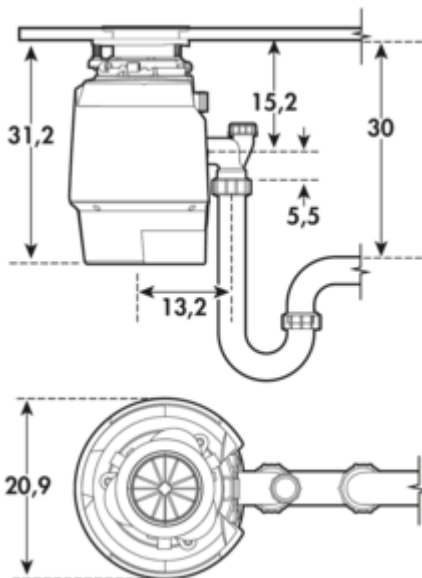

[more infos...](#)

Technical data

Article type	Kitchen waste disposal	Grinding chamber capacity	0,98 l
Height	312 mm	Diameter	209 mm
Width	209 mm	Shape	round
Material	stainless steel	Number of containers	1
Properties	Maintenance-free Self-cleaning	Total volume	0,98 l
Note	Before installing the waste disposal unit, please contact the competent authorities for information on the regional legal regulations!	Volume/content container 1	0,98 l
Material grinding chamber	stainless steel	Design	Kitchen waste disposals
Engine power	0.55 hp	Volume/Content container	0,98