

Under-sink device TR 1500

Product number: 6011041

Configuration: white

Configuration options

6011041 | white

- ✓ Hot water tank
- ✓ pressure-free (open)
- ✓ low pressure

Water heater.

- small water heater 5 litres, white. Open (pressure-free)
- container material in plastic
- high-quality compact insulation
- continuous temperature setting of 35–85 °C
- with frost protection setting "*" and energy-saving setting "e"
- temperature setting can be limited to stage "l" or stage "e"
- power indicator lamp
- mixed water volume 40 °C 9.5 l
- the outlet of a faucet should always be free
- if possible, do not use a shower fitting
- lowest standby power consumption (about 0,2 kWh at 65 °C/24 h)
- with fastening material, mounting bracket
- switchable safety temperature limiter
- contact/moisture protection IP24D
- power supply 220–240 V
- ready to plug in, connected load 2.2 kW
- weight with water 7.5 kg
- device dimensions (H x W x D) 390 x 258 x 245 mm

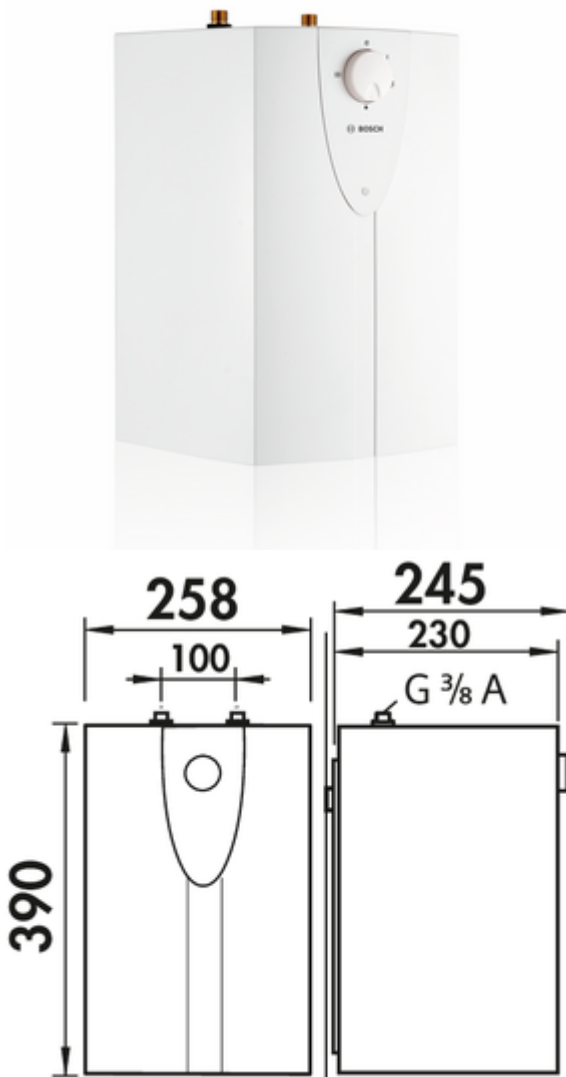

[more infos...](#)

Technical data

Article type	Hot water tank	Certification	CE VDE
Height	390 mm	Temperature setting	continuous temperature setting of 35–85 °C temperature setting can be limited to stage "l" or stage "e"
Operating pressure	low pressure	Print type	pressure-free (open)
Width	258 mm	Weight with water filling	16,53465 lb
Material	plastic	Under-sink unit version	high-quality compact insulation With frost protection setting "*" and energy saving position "e" switchable safety temperature limiter
Energy efficiency class	A	Standby energy consumption	about 0,2 kWh at 65 °C/24 h
Mains voltage	220–240 V	Mixed water quantity	40 °C 9.5 l
Protection class	IP24D	Volume/Content	5 l
Integrated display	power indicator lamp	Material container	plastic
Note	the outlet of a faucet should always be free if possible, do not use a shower fitting ready to plug in, connected load 2.2 kW	With mains plug	Yes
Operating mode	Cable		