

PRIME flow P-MAS 150 wall connector



Product number: 4051020

Configuration: light grey

Configuration options

4051020 | light grey

- ✓ Connecting element
- ✓ N-click system with integrated latching elements
- N-Klick system for secure connection with the universal connector
- adapter for connecting flat duct pipe and flat duct bends to P-MRBS 150 wall connector pipe set

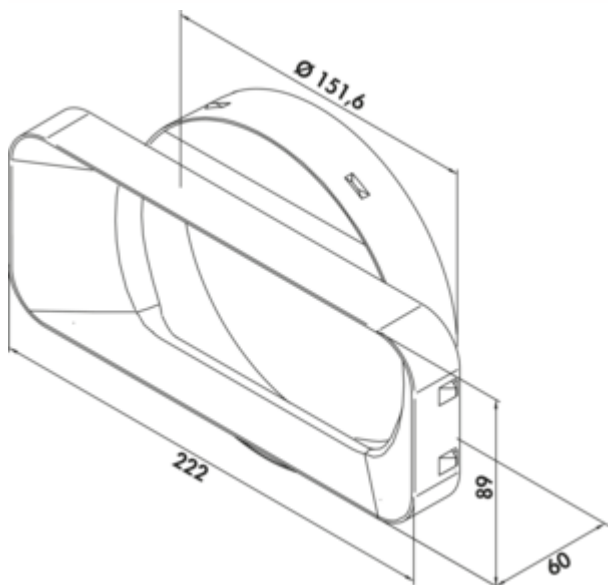

[more infos...](#)

Technical data

Article type	Connecting element	System dimension	150
Brand	PRIME flow	Output drive	angular round
Width	222 mm	Ventilation system	COMPAIR PRIME flow®
Mounting/Fixing	N-click system with integrated latching elements		

