

STEEL flow SR-KDA 150 condensing water separator



Product number: 4061021

Configuration: galvanized steel

Configuration options

4061021 | galvanized steel

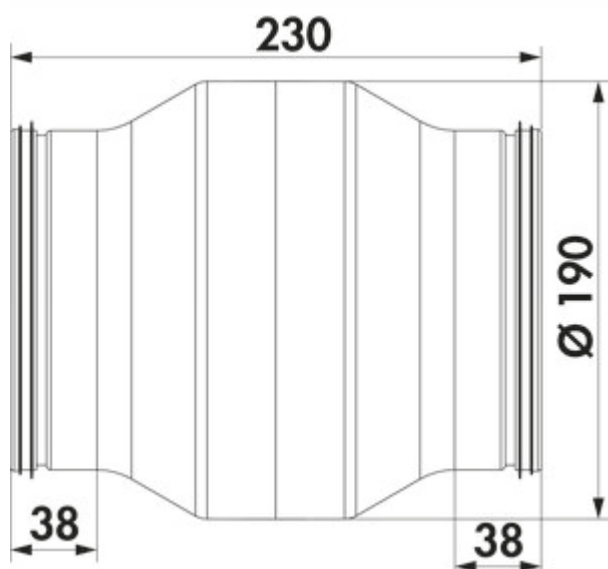

✓ Connecting element

✓ plug-in system

Prevents return flow of condensing water to the hood in case of vertical waste air routing. Flow-optimised design by avoiding sharp edges that stall the flow.

- filling volume 115.5 ml
- suitable for round pipes SR-R flex and SR-R
- connection to a plastic round pipe possible

[more infos...](#)

Technical data

Article type	Connecting element	Surface/coating	galvanised
Brand	STEEL flow	Shape	round
Warranty	5-year Naber warranty (except for wear parts); the general warranty conditions of Naber GmbH apply.	Outer diameter	150 mm
Width	230 mm	Filling volume	0,1155 l
Material	galvanized steel	System dimension	150
Mounting/Fixing	plug-in system	Output drive	round
Note	connection to a plastic round pipe possible	Ventilation system	COMPAIR STEEL flow® 150
Suitable for	suitable for round pipes SR-R flex and SR-R		

