

## Nava 2

Product number: 1015041

Configuration: stainless steel

### Configuration options

1015041 | stainless steel

1041062 | set (sink and Drive 1 faucet)

- ✓ Built-in sink
- ✓ Eccentric set
- ✓ 3½" basket strainer valve flush

Built-in sink. With draining surface, reversible. 3½" basket strainer valve flush, rotational excenter fitting.

— suitable for worktop thicknesses from 17 mm to 40 mm

— cut-out dimensions ca. 760 x 415 mm



[more infos...](#)

### Technical data

|                      |                                 |                                    |                              |
|----------------------|---------------------------------|------------------------------------|------------------------------|
| Article type         | Sink                            | Flushing radius (R)                | 10                           |
| Height               | 270 mm                          | Maximum worktop material thickness | 40 mm                        |
| Width                | 780 mm                          | Material thickness worktop minimum | 17 mm                        |
| Material             | stainless steel                 | Number of tap holes                | 1                            |
| Cabinet width        | 450 mm                          | Armature bench                     | Yes                          |
| Cut-out dimension    | approx. 760 x 415 mm            | Number of holes                    | 1                            |
| Excenter fitting     | Eccentric set                   | Arrangement sinks                  | Reversible                   |
| Valve type           | 3½" basket strainer valve flush | Number of sinks                    | 1 main sink                  |
| Overflow             | Overflow in the main basin      | Number of overflow points          | 1                            |
| Installation variant | Built-in sink                   | Draining board                     | With ribbed draining surface |
| Main sink width      | 340 mm                          | Garnish actuation                  | Rotational excenter          |
| Height main sink     | 145 mm                          | Pelvic inner radius (R)            | 95                           |
| Depth main sink      | 370 mm                          |                                    |                              |

### Spare Parts

|         |  |
|---------|--|
| 1010050 | Rotational excenter fitting, Drain fittings, 3½" basket strainer valve flush, for Nava 1–3 |
|---------|--|

## Recommendations

|         |  |
|---------|--|
| 5011060 | Drive 1, Sink faucet, chrome, high pressure                  |
| 1111141 | Stainless steel system care, Cleaning agent,                 |
| 1111142 | Stainless steel cleaning agent Utral, Cleaning agent, 250 ml |
| 1111143 | Stainless steel care agent Edelglanz, Cleaning agent, 250 ml |

Dimensional sketch (PDF)

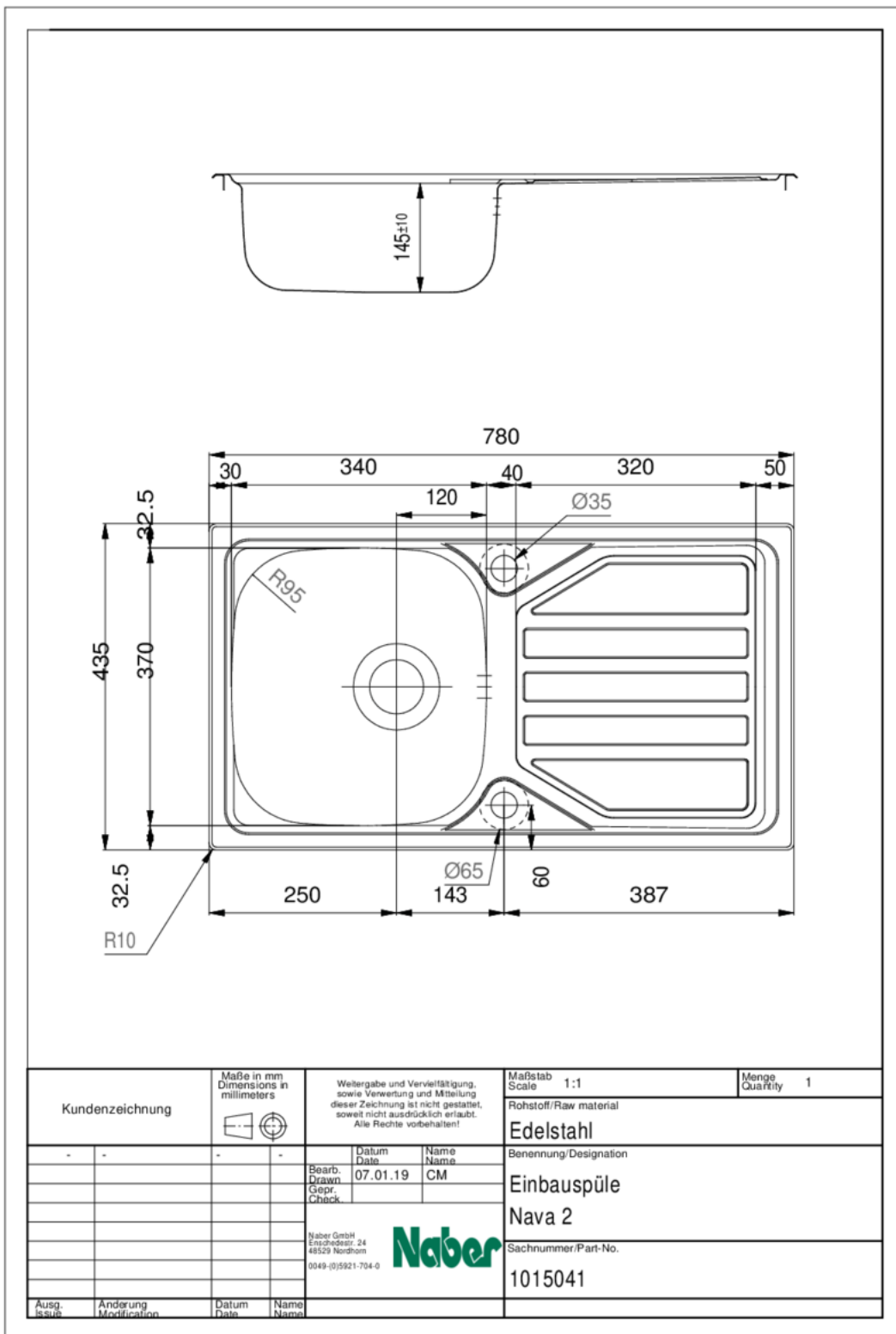

Installation dimensions (PDF)

