

Nava 2

Product number: 1015041

Configuration: stainless steel

Configuration options

1015041 | stainless steel

1041062 | set (sink and Drive 1 faucet)

- ✓ Built-in sink
- ✓ Eccentric set
- ✓ 3½" basket strainer valve flush

Built-in sink. With draining surface, reversible. 3½" basket strainer valve flush, rotational excenter fitting.

— suitable for worktop thicknesses from 17 mm to 40 mm

— cut-out dimensions ca. 760 x 415 mm



[more infos...](#)

Technical data

Article type	Sink	Flushing radius (R)	10
Width	780 mm	Maximum worktop material thickness	40 mm
Material	stainless steel	Material thickness worktop minimum	17 mm
Cabinet width	450 mm	Number of tap holes	1
Cut-out dimension	approx. 760 x 415 mm	Armature bench	Yes
Excenter fitting	Eccentric set	Number of holes	1
Valve type	3½" basket strainer valve flush	Arrangement sinks	Reversible
Overflow	Overflow in the main basin	Number of sinks	1 main sink
Installation variant	Built-in sink	Number of overflow points	1
Main sink width	340 mm	Draining board	With ribbed draining surface
Height main sink	145 mm	Garnish actuation	Rotational excenter
Depth main sink	370 mm	Pelvic inner radius (R)	95

Spare Parts

1010050	Rotational excenter fitting, Drain fittings, 3½" basket strainer valve flush, for Nava 1–3
---------	--

Recommendations

5011060	Drive 1, Sink faucet, chrome, high pressure
1111141	Stainless steel system care, Cleaning agent,
1111142	Stainless steel cleaning agent Utral, Cleaning agent, 250 ml
1111143	Stainless steel care agent Edelglanz, Cleaning agent, 250 ml

Dimensional sketch (PDF)

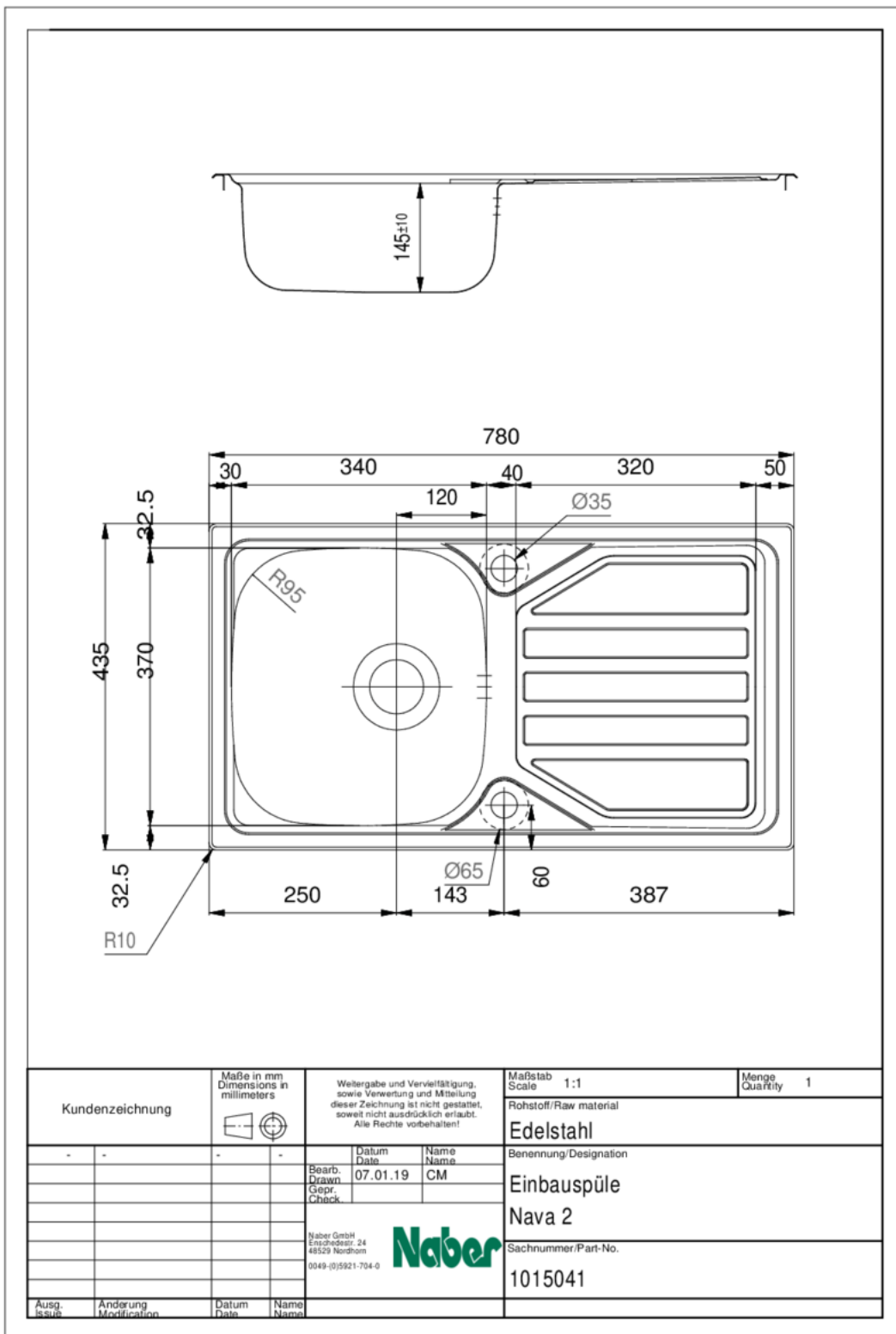

Installation dimensions (PDF)

