



PRIME flow P-Turbo flow 150 wall conduct incl. THERMOBOX

Product number: 4051065

Configuration: white, stainless steel

Configuration options

4051065 | white, stainless steel

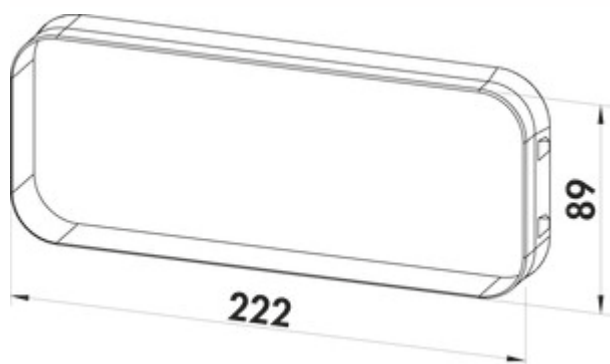

- ✓ Wall sleeve
- ✓ installation in the wall
- ✓ N-click system with integrated latching elements

Wall conduct, incl. THERMOBOX heat retention system and Turbo stainless steel external blind for installation close to the ground and for conventional installation at ceiling height.

Two-stage installation:

1. Assembly of the separately packaged construction kit
2. Toolless insertion of the heat retention system and the blind

- N-Klick system for secure connection with the universal connector
- direct connection of the flat adapter, round pipe or round pipe bends
- Blower-Door certified (necessary opening pressure >65 Pa)

Raw construction set:

- raw construction set for installation in the wall at any time
- max. wall thickness 550 mm, can be shortened to 220 mm
- core hole drilling in nominal \varnothing 162 or 164 mm
- hard foam plugs to protect against dirt during the construction phase
- wall sleeve for tool-free installation and sealing against leakage



[more infos...](#)

Technical data

Article type	Wall sleeve	Outer diameter	150 mm
Brand	PRIME flow	Suitable wall thickness	max. wall thickness 550 mm
Material	stainless steel/plastic	Wall box version	wall conduct, incl. THERMOBOX heat retention system and Turbo stainless steel external blind for installation close to the ground and for conventional installation at ceiling height
Properties	can be shortened	System dimension	150
Mounting/Fixing	installation in the wall N-click system with integrated latching elements	Output drive	angular
Suitable for	direct connection of the flat adapter, round pipe or round pipe bends	Ventilation system	COMPAIR PRIME flow [®]
Shortenability	can be shortened to 220 mm	Opening pressure	> 65 Pa
Shape	round	Rohbausset	raw construction set for installation in the wall at any time max. wall thickness 550 mm, can be shortened to 220 mm core hole drilling in nominal Ø 162 mm polystyrene plugs to protect against dirt during the construction phase wall sleeve for tool-free installation and sealing against leakage

Accessories

4051004	P-UVB 150 universal connector, Connecting element, light grey
---------	---

