



Premium 700 EC

Product number: 8012031

Configuration: anthracite, H 312 mm

Configuration options

8012031 | anthracite, H 312 mm

- ✓ Kitchen waste disposals
- ✓ Grinding chamber capacity: 0,98 l
- ✓ stainless steel

The kitchen waste disposal device may be continuously filled. Automatic change of rotational direction to extend the service life and for trouble-free use. Stainless steel grinding chamber 980 ml, low-noise, with enclosed air break switch in chrome, 2-way grinding process, overload switch with manual reset switch, splash-proof, GS connection, motor with 0.75 hp. Suitable for 3½" drains.

Before installing the waste disposal unit, please contact the competent authorities for information on the regional legal regulations!

- Ø 209 mm
- weight 8.12 kg
- 380 watt
- Drain connection: 3.8 cm
- Drill hole diameter for air valve: 35 mm

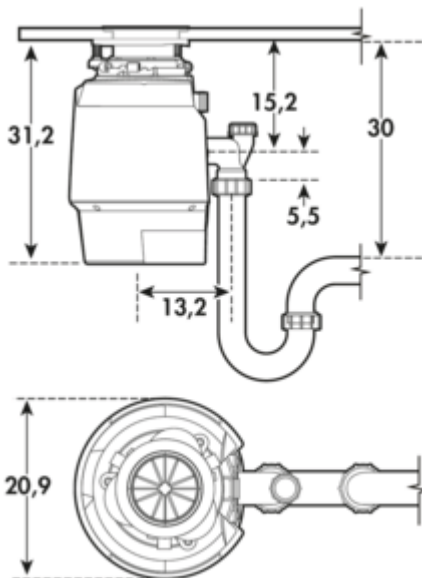

[more infos...](#)

Technical data

Article type	Kitchen waste disposal	Diameter	209 mm
Height	312 mm	Shape	round
Width	209 mm	Number of containers	1
Material	stainless steel	Total volume	1 l
Properties	Maintenance-free quiet Self-cleaning Splash-proof	Volume/content container 1	1 l
Note	Before installing the waste disposal unit, please contact the competent authorities for information on the regional legal regulations!	Design	Kitchen waste disposals
Material grinding chamber	stainless steel	Volume/Content container	1
Engine power	0.75 hp	Volume	40 % quieter than standard
Grinding chamber capacity	0,98 l		